



ARTICULATED BOOMS ELECTRIC

GENIE Z33/18



Hydraulic platforms and scissor lifts

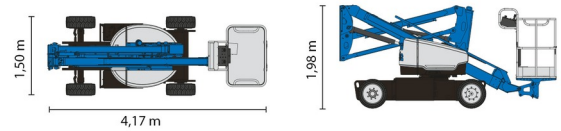
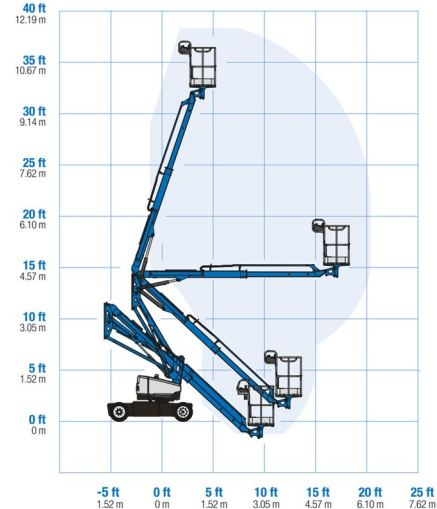

» GENIE Z33/18

Daily price	€ 145
2 to 4 days	€ 115 /day
Weekly price	€ 400
From 4 weeks	€ 305 /week

Working height	12,00 m
Loading capacity	200 kg
Length	4,17 m
Width	1,50 m
Height	1,98 m
Weight	3665 kg

ACCESSORIES

- Operator - CAT 1



- 1 socket in working platform
- Platform load outdoors: 2 persons
- Platform load indoors: 2 persons
- Battery
- Anti-entrapment system

Consult our website www.dumarent.be for the technical data sheet

If you have any questions about this machine or any accessory, please call us at +32(0)56 222 111 or send us an email.

There will be a cleaning and environmental charge if the machine is returned dirty or full of mud.

* All prices are VAT excluded.
* A deposit may be requested.

duma rent
on different places !

Duma Rent bvba - Torkonjestraat 23, BE-8510 Marke
T +32(0)56 222 111 • Fax +32(0)56 716 141
info@dumarent.be • www.dumarent.be

Region West-Flanders
056 222 111

Region East-Flanders
09 228 28 22

Region Antwerp
03 887 87 81

Region Brussels
02 705 05 09

Region Charleroi
071 33 36 38